

# ROYAL HORTICULTURAL SOCIETY

## CHELSEA FLOWER SHOW 2012

### FLORAL ARRANGEMENT: Regulations

For Floral Arrangers the Chelsea Show week is divided into two sessions, both lasting three days. The first session exhibits from Monday (Press Day) 21 to Wednesday 23 May. The second session exhibits from Thursday 24 to Saturday 26 May. Should your application be successful your session will be decided by ballot.

#### 1. **Participation:**

- We welcome applications from individual floral arrangers and floral arranging clubs and societies affiliated to the Royal Horticultural Society or the National Association of Flower Arrangement Societies. Entries from commercial enterprises will not be accepted.
- Allocations are decided by ballot
- No charge is made for exhibits in this section

#### 2. **Applications:**

- Applications, on the appropriate form, must be returned by Wednesday 30 November 2011.
- In late December, successful applicants will receive a letter of confirmation together with other details including the session (either first or second).

#### 3. **Themes:**

Class Type	Island or Background Exhibit	Number of People to stage	Staged under NAFAS Club/Society name or Individual	Title to be included (Y/N)
<b>Class A</b> <i>"60 Glorious Years"</i>	Background Exhibit	Maximum of 2 people	NAFAS Club or Society name	N
<b>Class B</b> <i>"Opening Ceremony"</i>	Background Exhibit	1 person	Individual	N
<b>Class C</b> <i>"I Have a Dream"</i>	Island Exhibit	Maximum of 2 people	NAFAS Club or Society name	Y
<b>Class D</b> <i>"Urban Space"</i>	Island Exhibit	1 person	Individual	Y

#### 4. Display materials:

- In each exhibit fresh and natural plant material must predominate
- Prohibited material: artificial plant material is not allowed
- While some dyed, surface coloured or manipulated (e.g. plaited, stapled, glossed, etc.) plant material may be used, exhibitors should remember that the Royal Horticultural Society's Shows are held to display excellence in plants and all other aspects of horticulture
- The Society does not permit the use of wild dug plants and moss. Use of cultivated moss will be allowed
- The RHS asks that all exhibitors consider issues of environmental sustainability when sourcing and selecting cut flowers for display
- No plant material or accessories may extend beyond the limits of the staging
- Conditions in the Floral Design Marquee can be warm, the marquee has a clear roof predominantly obscured by trees but your display may be exposed to some direct sunlight, please take this into account when planning your exhibit so the display looks fresh for the duration of your session.

#### 5. Staging:

##### Class A:

- Each exhibit will be staged on a base 1.83m (6 feet) wide, 1.22m (4 feet) deep raised 0.23m (9 inches) from floor level
- The base platform will have a background 1.98m (6 feet 6 inches) high measured from the top of the base (see diagram)
- The platform and background will be painted cream. The Pantone colour reference for the paint is Dulux Cream 45YY 83094.
- Exhibitors are not permitted to use their own painted backgrounds
- Attachments to the background are not permitted
- The exhibitors own lightweight drapes may be used, but must be hung over the top of the background staging or attached to or draped over the exhibitor's own free-standing secure support
- Class A will be viewed and judged from the front

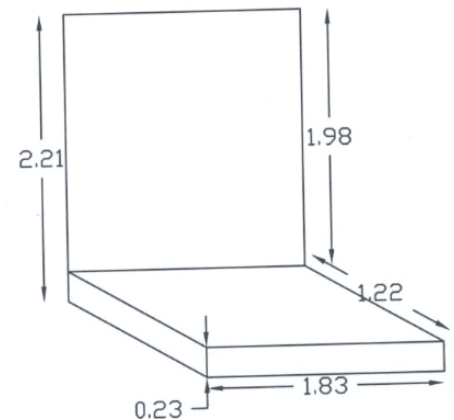

##### Class B:

- Each exhibit will be staged on a base 1.22m (4 feet) wide, 1.22m (4 feet) deep raised 0.23m (9 inches) from floor level
- The base platform will have a background 2.21m (7 feet 3 inches) high measured from the top of the base (see diagram)

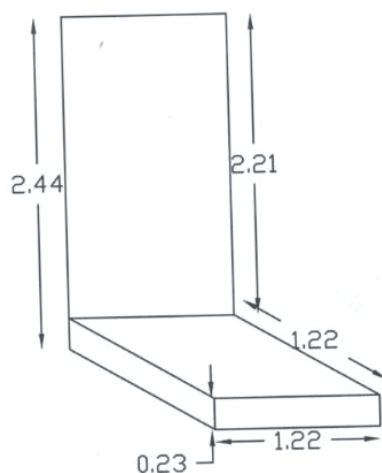

- The platform and background will be painted cream. The Pantone colour reference for the paint is Dulux Cream 45YY 83094.
- Exhibitors are not permitted to use their own painted backgrounds
- Attachments to the background are not permitted
- The exhibitor's own lightweight drapes may be used, but must be hung over the top of the background staging or attached to or draped over the exhibitor's own free-standing secure support.
- Class B will be viewed and judged from the front

### Class C:

- Each exhibit will be staged on a circular platform 1.22m (4 feet) in diameter raised 15cm (6 inches) from floor level
- The base will be painted cream. The Pantone colour reference for the paint is Dulux Cream 45YY 83094.
- Display height is optional but should not exceed 3m from the base
- Exhibitors' own drapes may be used
- Class C will be viewed and judged all around
- Title to be included

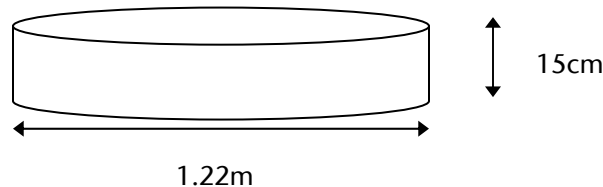

### Class D:

- Each exhibit will be staged on a square platform 1m (3.28 feet) wide by 1m (3.28 feet) deep raised 15cm (6 inches) from floor level
- The base will be painted cream. The Pantone colour reference for the paint is Dulux Cream 45YY 83094.
- Display height is optional but should not exceed 1m from the base
- Exhibitors' own drapes may be used
- Class D will be judged from the front but viewed from all sides
- Title to be included

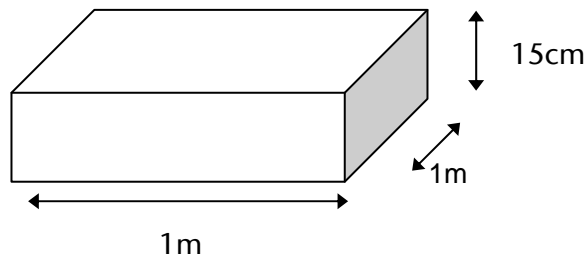

## 6. **Staging times:**

At the commencement of staging all personnel, other than the designated exhibitors, must leave the Floral Design Marquee. All exhibitors are required to wear high visibility jackets during staging.

### First Session

- Exhibitors may commence staging from 9.30pm on Sunday 20 May
- Exhibits must be completed by 6am on Monday 21 May
- The Floral Design Marquee will be open and lit throughout the night

### Second Session

- Exhibitors may commence staging from 9.45pm on Wednesday 23 May
- Staging must be completed by 6am on Thursday 24 May
- The Floral Design Marquee will be open and lit throughout the night

Any problems arising during staging should be directed to the NAFAS co-ordinator in the marquee, any unresolved issues must be put in writing to the Show Manager, no later than 7 days after the event.

## 7. **Judging and awards:**

During judging all personnel will be required to vacate the Floral Design Marquee. **The judging criteria is being reviewed by the Floristry & Flower Arranging sub committee on the 27 September 2011. All competitors will receive the updated judging criteria upon their confirmation of space.**

### First Session

- Exhibits will be judged on Monday 21 May
- Award cards and 'Best in Show' card will be placed on exhibits by 8.00am on Tuesday 22 May

### Second Session

- Exhibits will be judged on the morning of Thursday 24 May
- Award cards and 'Best in Show' card will be placed on the exhibits by noon or earlier if possible on Thursday 24 May

Floral Arrangement displays at the RHS Chelsea Flower Show will be judged on the following criteria:

- Quality and suitability of plant material. Please note rare or expensive plants or those that are difficult to grow will not, on that account, be considered more meritorious than those that are common or easily grown
- Good colour combination and balance
- Overall effect, and the skill with which the arrangement has been staged
- Manipulation of plant material will be allowed providing the mechanics do not show. Unattractive mutilation of plant material will be down-pointed
- Consideration will be given to the suitability of containers but otherwise no account will be taken of their decorative or intrinsic value
- The use of articles unrelated to the theme will be regarded as detracting from the value of the exhibit

### **Judging of floral arrangement exhibits at the Royal Horticultural Society's Shows is by RHS criteria and NOT by NAFAS regulations**

- The judge's decision is final and no correspondence will be entered into
- A representative of the judging panel will be available at the NAFAS table in the Floral Design Marquee for the First Session from 11.30am to 12.30pm on Tuesday 22 May and for the Second Session from 2.30pm to 3.30pm on Thursday 24 May, to talk to exhibitors who wish to discuss their exhibits or seek advice on how to improve them
- Exhibitors wishing to talk to a Judge should complete a feedback form provided to exhibitors on the day of judging

### **8. RHS Medals:**

- Floral arrangement displays at Chelsea are eligible for RHS medals: the RHS Gold Medal award, and the Silver-Gilt, Silver and Bronze medals in the Grenfell range
- If an exhibit is considered to be below Bronze standard, no award will be made
- The first time an exhibitor is awarded an RHS Gold Medal, the medal is provided by the Society. Medals for any other or subsequent awards are not provided but may be purchased
- Award cards will be placed on the exhibits (two for Classes A and C, one for Classes B and D). Any additional cards may be ordered from the RHS at a nominal charge.
- Best Exhibit: In each of the two sessions the best exhibit will be awarded a special glass trophy which may be retained by the award-winning exhibitor. These will be presented at the winning exhibit at 12.45pm on Tuesday 22 May to the First Session winner and at 3.45pm on Thursday 24 May to the Second Session winner. All exhibitors are encouraged to be in the Floral Design Marquee for the presentations
- Winners who cannot be present at those times should notify the NAFAS representative in the Floral Design Marquee as early as possible

9. **Maintenance of exhibit:**

- After judging has taken place, nothing may be added to the exhibit nor may anything be removed or altered, except faded cut flowers or other plant material which may be replaced with similar fresh flowers or plant material
- Maintenance of exhibits, including watering, must be done in the mornings before the show opens (Tuesday to Saturday) from 6am to 7.30am entry by vehicle, 7-7.45am entry on foot. No vehicles are permitted in the Showground after 7.30am.

10. **Name boards and sponsorship boards:**

- One credit board, maximum 230mm x 150mm (9 inches x 6 inches) which may bear the name(s) of your sponsor(s), if any, may be placed on your exhibit
- No other labels or notices except the title of the exhibit are allowed
- A board bearing the name of the exhibitor, club or society will be provided by the RHS and placed, together with your credit board, on the exhibit after judging has taken place

11. **Clearing:**

- All green waste should be placed in the recycling bins that will be provided outside the marquee on breakdown nights. All other rubbish and materials brought by the exhibitor must be removed by them at the end of each session
- Black sacks to assist clearance will be provided
- First Session exhibits must be cleared between 8.30pm and 9.30pm on Wednesday 23 May - **the RHS will not accept responsibility for any exhibit in this section which has not been cleared by 9.30pm**
- Second Session exhibits must be cleared on Saturday 26 May. Sell off commences at 4pm, however, we request you do not sell off from your exhibits. Clearance will commence at **5.30pm** and will be subject to the marquee being clear of visitors at that time. RHS staff will be available to help trolley floral arrangers' equipment and materials out of the Showground (Please note that this time will be subject to change depending on the number of visitors still in the showground at this time). **The RHS will not accept responsibility for any exhibit in this section which has not been cleared by 6.30pm**

12. **Liability for Loss:**

**Exhibits and exhibitors' property will, at all times, be at the risk of the exhibitor and the Royal Horticultural Society will not be liable for compensation for loss or damage from any cause whatsoever.**

13. **RHS Chelsea Flower Show Manual:**

- The Manual contains detailed information about the showground facilities and application forms for other services you may require. It will be sent to successful applicants in January 2011

If you have any queries relating to this schedule, please contact Sarah Easter, Deputy Show Manager at the RHS offices: Tel: 020 7821 3336 or saraheaster@rhs.org.uk

**September 2011**

**PLEASE SEE KEY CONTACTS LIST OVERLEAF**

## RHS CHELSEA FLOWER SHOW 2012

### FLORAL ARRANGEMENT: Key Contacts

If your query relates to one of the categories below, please use the relevant direct dial phone number:

**ALLOCATIONS, STAGING & ONSITE CONTACT**

***Sarah Easter, Deputy Show Manager (Maternity Cover)***  
Tel: 020 7821 3336  
Email: saraheaster@rhs.org.uk  
Fax : 020 7821 3660

**APPLICATION FORMS, CHANGE OF CONTACT DETAILS, BADGE AND PASSES ALLOCATIONS**

***Rachel Taylor, Exhibitor Services Coordinator***  
Tel: 020 7821 3008  
Email: rachel.taylor@rhs.org.uk  
Fax: 020 7821 3660

**GENERAL ENQUIRIES**

***Alexandra Denman, RHS Chelsea Show Manager***  
Tel: 020 7821 3333  
Email: alexdenman@rhs.org.uk  
Fax: 020 7821 3660

**GENERAL ENQUIRIES**

***Clare Greene, Deputy Show Manager***  
(Core days Tuesday-Thursday)  
Tel: 020 7821 3682  
Email: claregreene@rhs.org.uk  
Fax : 020 7821 3660

**TECHNICAL/OPERATIONAL DETAILS INCLUDING HEALTH & SAFETY ISSUES, SERVICES AND FACILITIES**

***Joanna Stewart, Deputy Operations Manager***  
Tel: 020 7821 3665  
Email: joannastewart@rhs.org.uk  
Fax: 020 7821 3660

**PRESS & PR INFORMATION**

***Press Office***  
Tel: 020 7821 3043  
Email: showspr@rhs.org.uk  
Fax: 020 7233 9502

**MARKETING**

***Marketing Office***  
Tel: 020 7821 3686  
Email: showsmarketing@rhs.org.uk  
Fax: 020 7233 9502

**ACCOUNTS**

***Accounts Assistant***  
Tel: 01483 479743  
Fax: 01483 212399

Shows Department general telephone number: 0845 370 0148